

# Return Air Grille

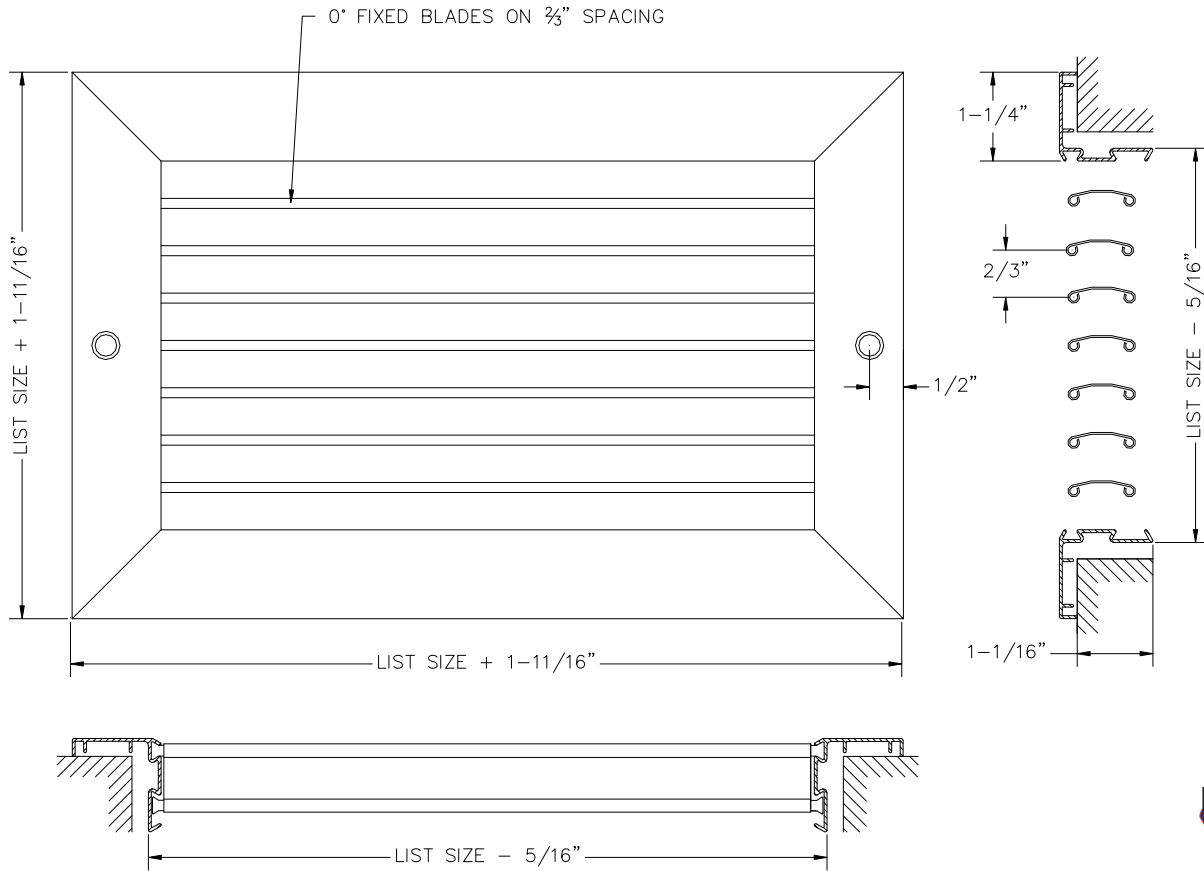

## DARH-S

- Horizontal blades fixed on 0° deflection and 2/3" spacing
- Aluminum rollformed blade providing a stylish appearance
- Pressure fit nylon pivot pins (rattle free & non loosening)
- Aluminum extruded frame with mechanically locked corners
- Countersunk screwholes c/w painted mounting screws
- Available on 2+increments as standard
- Custom sizes available but extra charge may apply
- Max blade length is 22+ Mullions used for larger sizes
- Durable powdercoat painted finish
- Available in White, Silver or Mill



DESCRIPTION	DARH-S
FACE BLADES	Horizontal Fixed 0°
REAR BLADES	n/a
DAMPER	n/a
MATERIAL	Aluminum
COLOR	White/Silver/Mill

JOB NAME: \_\_\_\_\_

LOCATION: \_\_\_\_\_

ARCHITECT: \_\_\_\_\_

ENGINEER: \_\_\_\_\_

CONTRACTOR: \_\_\_\_\_