

- $\frac{1}{2}'' \times \frac{1}{2}'' \times 1''$ aluminum eggcrate core.
- Opposed blade damper with slide operator.
- High quality aluminum extruded frame.
- Countersunk #6 screw hole mounting c/w painted screws.
- Mullions used for sizes over 48" in length.
- Available on 2" increments as standard. Custom sizes available down to 1/16" increments.
- Available with durable powder coat finish.

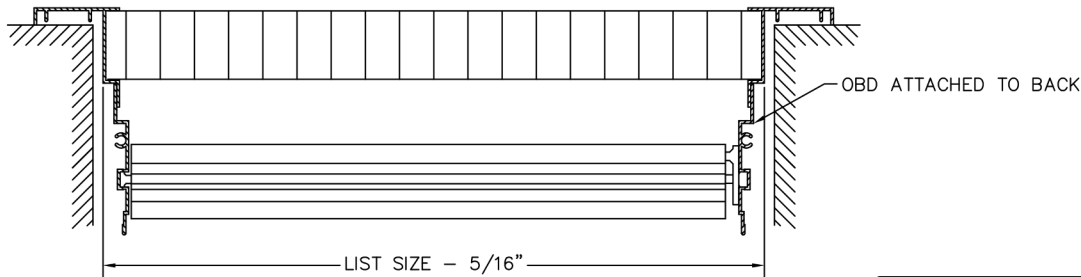
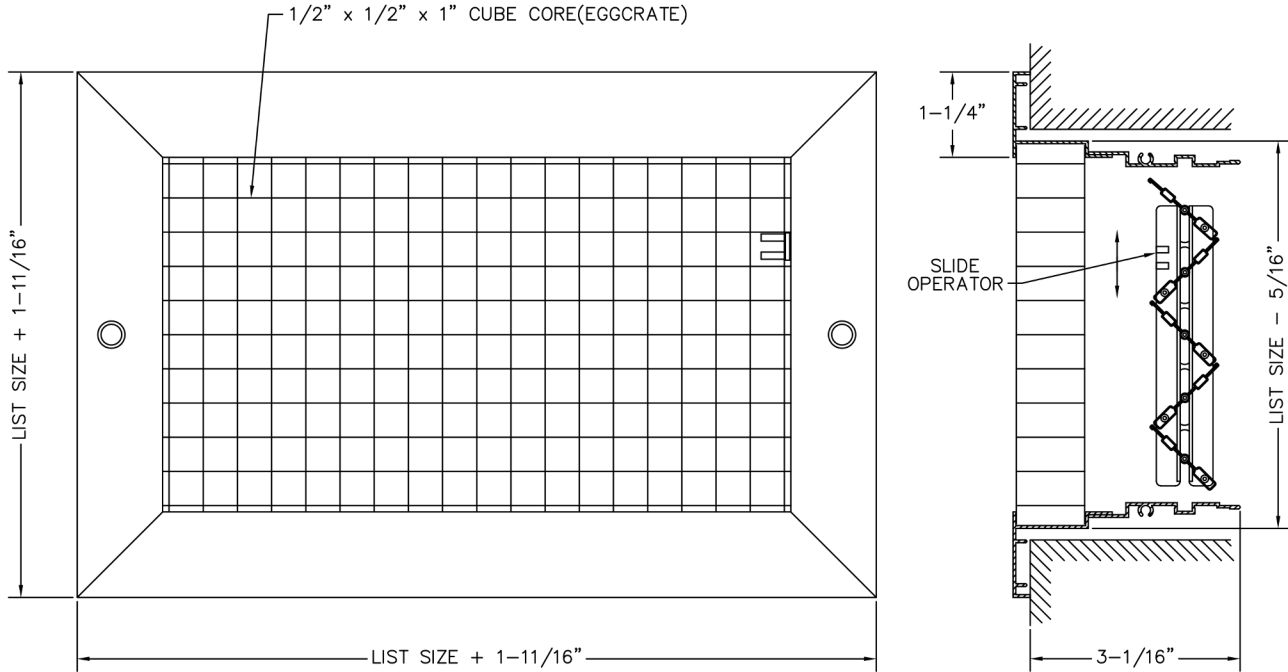

3 DAY SHIP
ANY SIZE. ANY MODEL. GUARANTEED

Additional Options

TB - No Screw Holes

AA - All Aluminum

1. Specify the Length x Height Dimensions

Inches MM _____ x _____

2. Select a Finish

W - White

S - Silver

M - Mill

3. Select a Lead Time

3 Day Ship

Next Friday

Standard Delivery

Project / Location: _____

Architect: _____

Engineer: _____

Contractor: _____

