

- Heavy-duty, extruded aluminum flange frame.
- Fully-extruded aluminum louver with fixed 30° horizontal blades on 3/4" spacing.
- Supports are hidden behind blades for a clean appearance.
- Bird screen included standard. Insect screen can be specified.
- Mounting available for PTAC / VTAC application.
- High-quality powder coat paint as standard (AAMA 2604). Architectural-grade finish available (AAMA 2605).
- High free area for optimal performance.

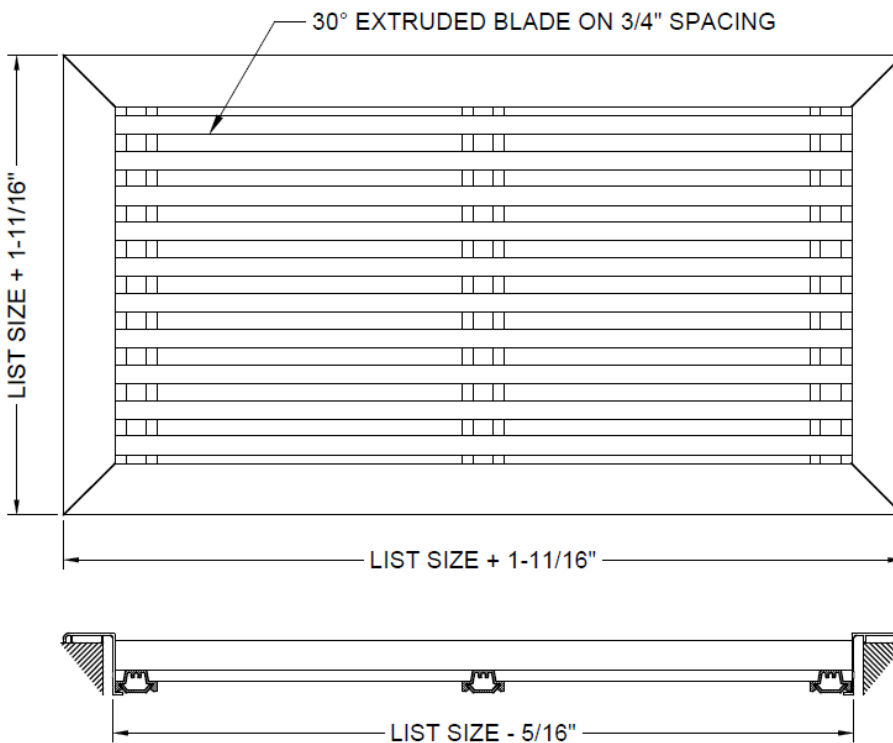

Standard Construction

Y Blade Option

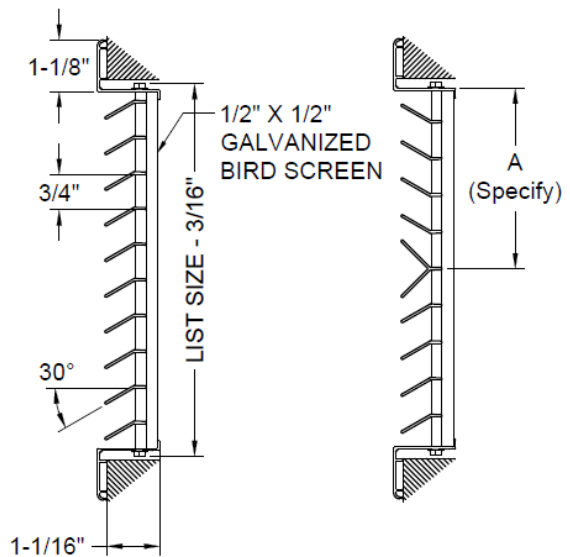

3 DAY SHIP
ANY SIZE. ANY MODEL.
GUARANTEED

1. Specify Quantity

2. Specify the Length x Height Dimensions

Available on 1" increments as standard. Custom sizes down to 1/16" increments.

_____ x _____ inches mm

3. Select a Finish

AAMA 2605 powder coat finish available upon request.

- W - White
- S - Silver
- B - Brown
- M - Mill
- FB - Flat Black
- Special

4. Select a Lead Time

- 3 Day Ship
- Next Friday
- Standard Delivery

Additional Options

- Y - Y Blade Must specify location.
- CO - Cut-Out Must specify location.
- IS - Insect Screen
- A - Mounting Holes
- B - Rear Wall Sleeve Mount Mounting configuration drawing needed.

Project / Location:

Architect:

Engineer:

Contractor:



Scan for more product information.

Mounting

-A

Mounting Holes

Mounting Holes
on Frame

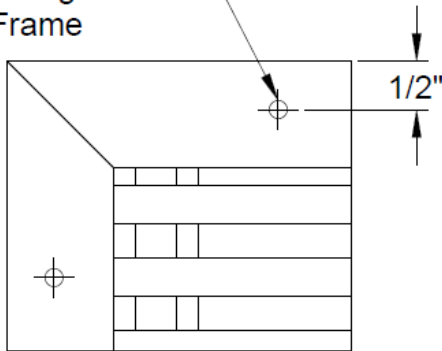

-B

Rear Wall Sleeve Mounting

Specifying drawing of hole locations required.

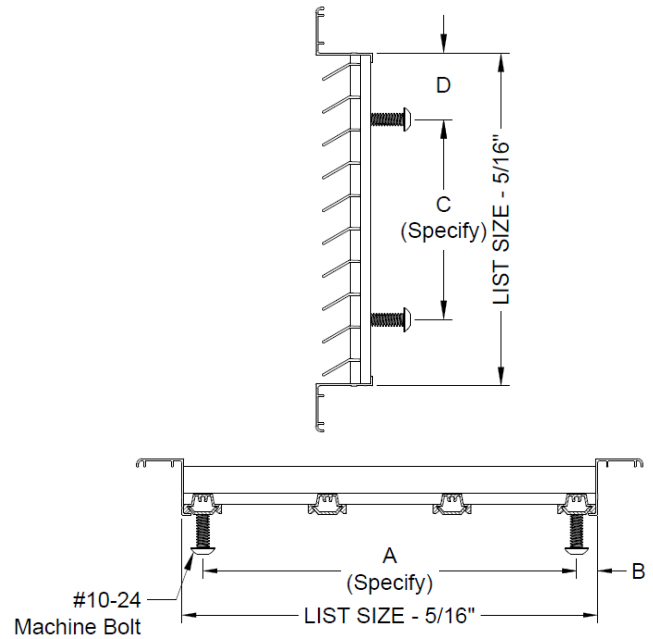

Special Options

Specifying drawings required.

Y-Blade

For combination intake/exhaust units.

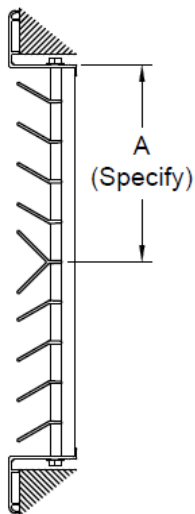

Notch Cut-Out

To accommodate retrofit wall sleeves with no depth for louver.

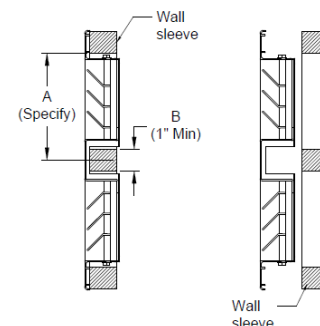

Scan for more
product
information.

Free Area ft² (m²)

OPENING LENGTH inches (mm)

	12	18	24	30	36	42	48	54	60	66	72	78	84	90	96	102	108	114	120
	300	450	600	750	900	1050	1200	1350	1500	1700	1850	2000	2150	2300	2450	2600	2750	2900	3050
8	0.40	0.64	0.85	1.10	1.34	1.55	1.80	2.05	2.25	2.50	2.75	2.96	3.20	3.45	3.66	3.90	4.15	4.36	4.60
200	0.04	0.06	0.08	0.10	0.12	0.14	0.17	0.19	0.21	0.23	0.26	0.27	0.30	0.32	0.34	0.36	0.39	0.40	0.43
12	0.61	0.98	1.30	1.67	2.05	2.37	2.74	3.12	3.43	3.81	4.18	4.50	4.88	5.25	5.57	5.94	6.32	6.64	7.01
300	0.06	0.09	0.12	0.16	0.19	0.22	0.25	0.29	0.32	0.35	0.39	0.42	0.45	0.49	0.52	0.55	0.59	0.62	0.65
16	0.83	1.34	1.77	2.28	2.79	3.22	3.73	4.24	4.67	5.18	5.69	6.12	6.63	7.14	7.58	8.08	8.59	9.03	9.54
450	0.08	0.12	0.16	0.21	0.26	0.30	0.35	0.39	0.43	0.48	0.53	0.57	0.62	0.66	0.70	0.75	0.80	0.84	0.89
20	1.05	1.69	2.24	2.88	3.53	4.07	4.72	5.36	5.91	6.55	7.20	7.75	8.39	9.03	9.58	10.23	10.87	11.42	12.06
600	0.10	0.16	0.21	0.27	0.33	0.38	0.44	0.50	0.55	0.61	0.67	0.72	0.78	0.84	0.89	0.95	1.01	1.06	1.12
24	1.27	2.04	2.71	3.49	4.26	4.93	5.71	6.49	7.15	7.93	8.71	9.37	10.15	10.93	11.59	12.37	13.15	13.81	14.59
750	0.12	0.19	0.25	0.32	0.40	0.46	0.53	0.60	0.66	0.74	0.81	0.87	0.94	1.02	1.08	1.15	1.22	1.28	1.36
28	1.48	2.40	3.18	4.09	5.00	5.78	6.70	7.61	8.39	9.30	10.21	10.99	11.91	12.82	13.60	14.51	15.42	16.20	17.12
900	0.14	0.22	0.30	0.38	0.46	0.54	0.62	0.71	0.78	0.86	0.95	1.02	1.11	1.19	1.26	1.35	1.43	1.51	1.59
32	1.70	2.75	3.65	4.69	5.74	6.64	7.68	8.73	9.63	10.67	11.72	12.62	13.66	14.71	15.61	16.65	17.70	18.60	19.64
1050	0.16	0.26	0.34	0.44	0.53	0.62	0.71	0.81	0.89	0.99	1.09	1.17	1.27	1.37	1.45	1.55	1.64	1.73	1.83
36	1.91	3.09	4.09	5.27	6.45	7.45	8.63	9.80	10.81	11.98	13.16	14.16	15.34	16.52	17.52	18.70	19.87	20.88	22.05
1200	0.18	0.29	0.38	0.49	0.60	0.69	0.80	0.91	1.00	1.11	1.22	1.32	1.43	1.53	1.63	1.74	1.85	1.94	2.05
40	2.13	3.44	4.56	5.87	7.18	8.30	9.61	10.93	12.04	13.36	14.67	15.79	17.10	18.41	19.53	20.84	22.15	23.27	24.58
1350	0.20	0.32	0.42	0.55	0.67	0.77	0.89	1.01	1.12	1.24	1.36	1.47	1.59	1.71	1.81	1.94	2.06	2.16	2.28
44	2.35	3.80	5.03	6.48	7.92	9.16	10.60	12.05	13.28	14.73	16.17	17.41	18.85	20.30	21.53	22.98	24.43	25.66	27.11
1500	0.22	0.35	0.47	0.60	0.74	0.85	0.99	1.12	1.23	1.37	1.50	1.62	1.75	1.89	2.00	2.13	2.27	2.38	2.52
48	2.57	4.15	5.50	7.08	8.66	10.01	11.59	13.17	14.52	16.10	17.68	19.03	20.61	22.19	23.54	25.12	26.70	28.05	29.63
1700	0.24	0.39	0.51	0.66	0.80	0.93	1.08	1.22	1.35	1.50	1.64	1.77	1.91	2.06	2.19	2.33	2.48	2.61	2.75
52	2.79	4.50	5.97	7.68	9.40	10.86	12.58	14.29	15.76	17.47	19.19	20.65	22.37	24.09	25.55	27.27	28.98	30.45	32.16
1850	0.26	0.42	0.55	0.71	0.87	1.01	1.17	1.33	1.46	1.62	1.78	1.92	2.08	2.24	2.37	2.53	2.69	2.83	2.99
56	3.01	4.86	6.44	8.29	10.14	11.72	13.57	15.42	17.00	18.85	20.70								
2000	0.28	0.45	0.60	0.77	0.94	1.09	1.26	1.43	1.58	1.75	1.92								
60	3.22	5.20	6.88	8.86	10.84	12.53	14.51	16.49	18.18	20.16	22.13								
2150	0.30	0.48	0.64	0.82	1.01	1.16	1.35	1.53	1.69	1.87	2.06								
64	3.44	5.55	7.35	9.47	11.58	13.38	15.50	17.61	19.42	21.53	23.64								
2300	0.32	0.52	0.68	0.88	1.08	1.24	1.44	1.64	1.80	2.00	2.20								
68	3.65	5.90	7.82	10.07	12.32	14.24	16.49	18.73	20.65	22.90	25.15								
2450	0.34	0.55	0.73	0.94	1.14	1.32	1.53	1.74	1.92	2.13	2.34								
72	3.87	6.26	8.29	10.67	13.06	15.09	17.48	19.86	21.89	24.28	26.66								
2600	0.36	0.58	0.77	0.99	1.21	1.40	1.62	1.84	2.03	2.26	2.48								
76	4.09	6.61	8.76	11.28	13.80	15.95	18.46	20.98	23.13	25.65	28.17								
2750	0.38	0.61	0.81	1.05	1.28	1.48	1.72	1.95	2.15	2.38	2.62								
80	4.31	6.96	9.23	11.88	14.53	16.80	19.45	22.10	24.37	27.02	29.67								
2900	0.40	0.65	0.86	1.10	1.35	1.56	1.81	2.05	2.26	2.51	2.76								
84	4.52	7.30	9.68	12.46	15.24	17.61	20.39	23.17	25.55	28.33	31.11								
3050	0.42	0.68	0.90	1.16	1.42	1.64	1.89	2.15	2.37	2.63	2.89								

Pressure Drop Louver test size 48" x 48" (120mm x 120mm).

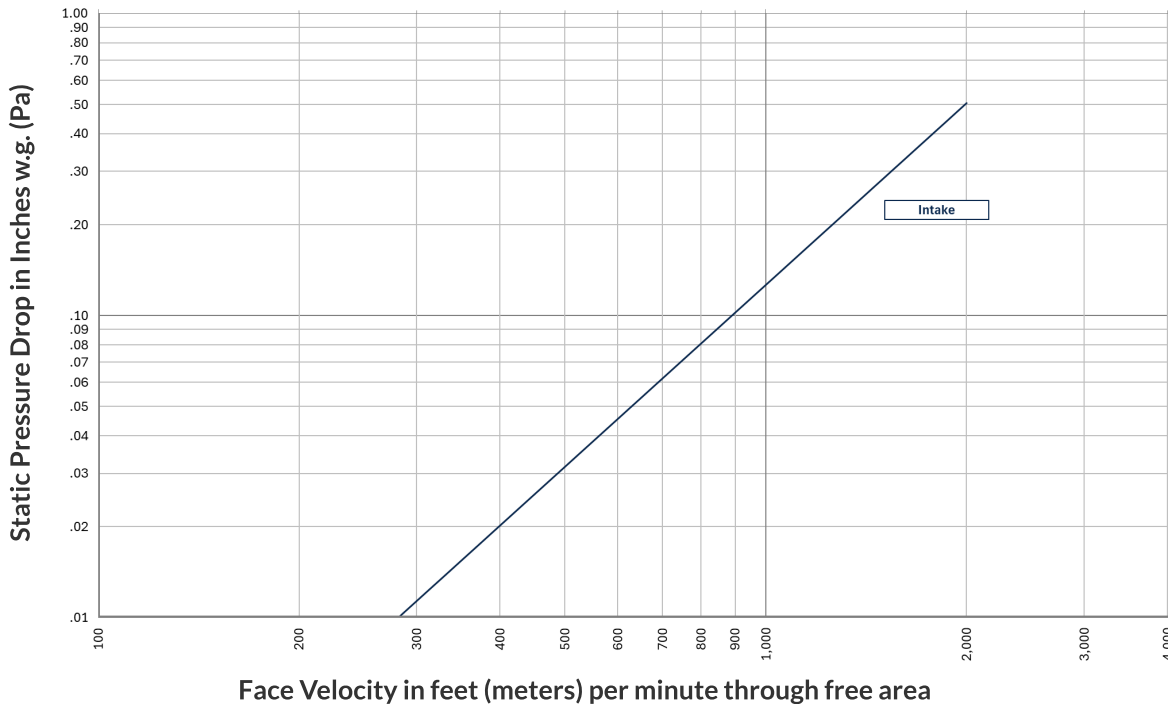

Scan for more product information.