

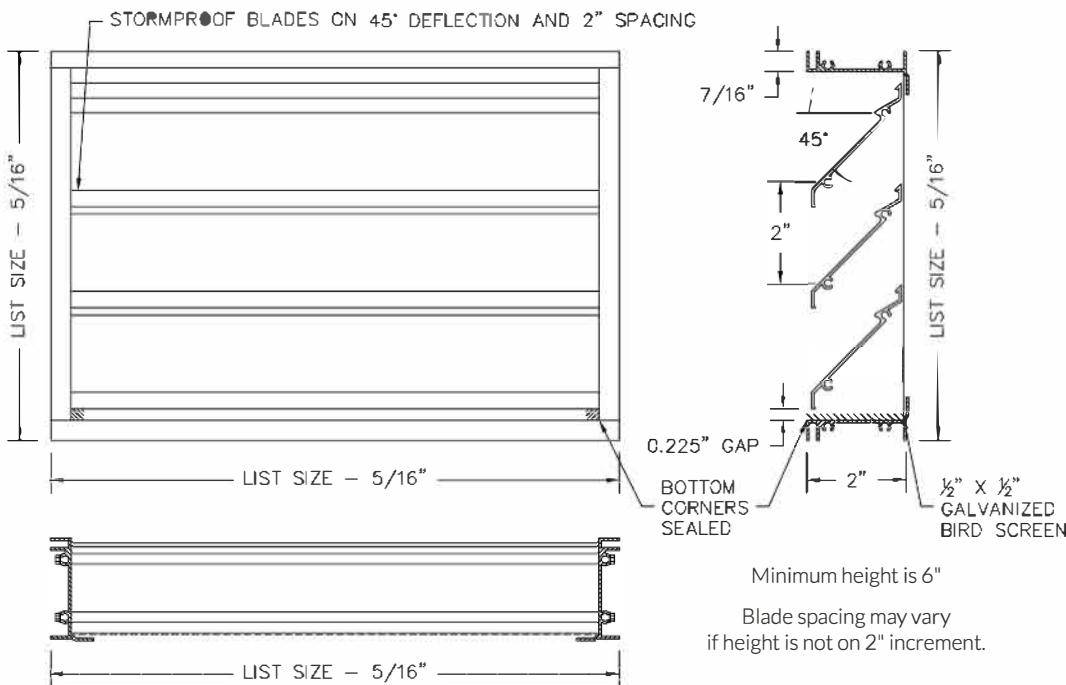

- Heavy-duty, extruded aluminum channel frame.
- Fixed, non-drainable blade on 2" spacing.
- J-blade design minimizes water ingress while maximizing free area.
- Nominal 43% free area, based on 48" x 48" louver.
- Mullions used for sizes over 36" in length.
- Bird screen included standard. Insect screen can be specified.
- Available with AAMA 2605 powder coat paint for high-performance exterior finishes.



Standard Construction

Material	6063-T5
Blade Angle	45°
Blade Spacing	2"
Mullion Start	36"
Minimum Size	3 x 6"

1. Specify Quantity

2. Specify the Length x Height Dimensions

Available on 1" increments as standard. Custom sizes down to 1/16" increments.

_____ x _____ inches mm

3. Select a Finish

- W - White
- S - Silver
- B - Brown
- M - Mill

- FB - Flat Black
- AAMA 2605
Powder Coat
- Special:

4. Select a Lead Time

- 3 Day Ship
- Next Friday
- Standard Delivery

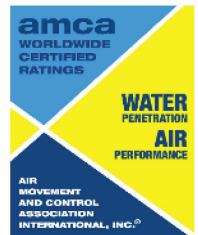

Additional Options

- IS - Insect Screen
- ES - Extended Sill - Open Ends
- SP - Sill Pan - Closed Ends



Project / Location:

Architect:

Engineer:

Contractor:



Scan for more product information.

Free Area ft² (m²)

OPENING LENGTH inches (mm)

		12	18	24	30	36	42	48	54	60	66	72	78	84	90	96	102	108	114	120					
		300	450	600	750	900	1050	1200	1350	1500	1700	1850	2000	2150	2300	2450	2600	2750	2900	3050					
8		0.16	0.26	0.36	0.45	0.55	0.61	0.71	0.81	0.90	1.00	1.10	1.16	1.26	1.36	1.45	1.55	1.65	1.71	1.81					
	200	0.02	0.02	0.03	0.04	0.05	0.06	0.07	0.08	0.08	0.09	0.10	0.11	0.12	0.13	0.14	0.14	0.15	0.16	0.17					
12		0.30	0.48	0.66	0.84	1.02	1.15	1.33	1.51	1.69	1.87	2.05	2.17	2.35	2.53	2.71	2.89	3.07	3.20	3.38					
	300	0.03	0.04	0.06	0.08	0.10	0.11	0.12	0.14	0.16	0.17	0.19	0.20	0.22	0.24	0.25	0.27	0.29	0.30	0.31					
18		0.51	0.82	1.12	1.43	1.74	1.94	2.25	2.56	2.86	3.17	3.48	3.68	3.99	4.29	4.60	4.91	5.21	5.42	5.73					
	450	0.05	0.08	0.10	0.13	0.16	0.18	0.21	0.24	0.27	0.29	0.32	0.34	0.37	0.40	0.43	0.46	0.48	0.50	0.53					
24		0.72	1.15	1.59	2.02	2.45	2.74	3.17	3.60	4.04	4.47	4.90	5.19	5.62	6.06	6.49	6.92	7.35	7.64	8.08					
	600	0.07	0.11	0.15	0.19	0.23	0.25	0.29	0.33	0.38	0.42	0.46	0.48	0.52	0.56	0.60	0.64	0.68	0.71	0.75					
30		0.93	1.49	2.05	2.61	3.16	3.54	4.10	4.65	5.21	5.77	6.33	6.70	7.26	7.82	8.38	8.94	9.49	9.87	10.42					
	750	0.09	0.14	0.19	0.24	0.29	0.33	0.38	0.43	0.48	0.54	0.59	0.62	0.67	0.73	0.78	0.83	0.88	0.92	0.97					
36		1.14	1.82	2.51	3.19	3.88	4.33	5.02	5.70	6.39	7.07	7.76	8.21	8.90	9.58	10.26	10.95	11.63	12.09	12.77					
	900	0.11	0.17	0.23	0.30	0.36	0.40	0.47	0.53	0.59	0.66	0.72	0.76	0.83	0.89	0.95	1.02	1.08	1.12	1.19					
42		1.35	2.16	2.97	3.78	4.59	5.13	5.94	6.75	7.56	8.37	9.18	9.72	10.53	11.34	12.15	12.96	13.77	14.31	15.12					
	1050	0.13	0.20	0.28	0.35	0.43	0.48	0.55	0.63	0.70	0.78	0.85	0.90	0.98	1.05	1.13	1.20	1.28	1.33	1.41					
48		1.56	2.50	3.43	4.37	5.30	5.93	6.86	7.80	8.74	9.67	10.61	11.23	12.17	13.10	14.04	14.98	15.91	16.54	17.47					
	1200	0.14	0.23	0.32	0.41	0.49	0.55	0.64	0.72	0.81	0.90	0.99	1.04	1.13	1.22	1.30	1.39	1.48	1.54	1.62					
54		1.77	2.83	3.89	4.96	6.02	6.73	7.79	8.85	9.91	10.97	12.04	12.74	13.80	14.87	15.93	16.99	18.05	18.76	19.82					
	1350	0.16	0.26	0.36	0.46	0.56	0.62	0.72	0.82	0.92	1.02	1.12	1.18	1.28	1.38	1.48	1.58	1.68	1.74	1.84					
60		1.98	3.17	4.36	5.54	6.73	7.52	8.71	9.90	11.09	12.27	13.46	14.25	15.44	16.63	17.82	19.00	20.19	20.98	22.17					
	1500	0.18	0.29	0.40	0.51	0.63	0.70	0.81	0.92	1.03	1.14	1.25	1.32	1.43	1.54	1.66	1.77	1.88	1.95	2.06					
66		2.19	3.50	4.82	6.13	7.44	8.32	9.63	10.95	12.26	13.57	14.89	15.76	17.08	18.39	19.70	21.02	22.33	23.21	24.52					
	1700	0.20	0.33	0.45	0.57	0.69	0.77	0.89	1.02	1.14	1.26	1.38	1.46	1.59	1.71	1.83	1.95	2.07	2.16	2.28					
72		2.40	3.84	5.28	6.72	8.16	9.12	10.56	12.00	13.44	14.88	16.31	17.27	18.71	20.15	21.59	23.03	24.47	25.43	26.87					
	1850	0.22	0.36	0.49	0.62	0.76	0.85	0.98	1.11	1.25	1.38	1.52	1.60	1.74	1.87	2.01	2.14	2.27	2.36	2.50					
78		2.61	4.17	5.74	7.31	8.87	9.91	11.48	13.04	14.61	16.18	17.74													
	2000	0.24	0.39	0.53	0.68	0.82	0.92	1.07	1.21	1.36	1.50	1.65													
84		2.82	4.51	6.20	7.89	9.58	10.71	12.40	14.09	15.79	17.48	19.17													
	2150	0.26	0.42	0.58	0.73	0.89	1.00	1.15	1.31	1.47	1.62	1.78													
90		3.03	4.85	6.66	8.48	10.30	11.51	13.33	15.14	16.96	18.78	20.59													
	2300	0.28	0.45	0.62	0.79	0.96	1.07	1.24	1.41	1.58	1.74	1.91													
96		3.24	5.18	7.12	9.07	11.01	12.31	14.25	16.19	18.13	20.08	22.02													
	2450	0.30	0.48	0.66	0.84	1.02	1.14	1.32	1.50	1.68	1.87	2.05													
102		3.45	5.52	7.59	9.65	11.72	13.10	15.17	17.24	19.31	21.38	23.45													
	2600	0.32	0.51	0.70	0.90	1.09	1.22	1.41	1.60	1.79	1.99	2.18													
108		3.66	5.85	8.05	10.24	12.44	13.90	16.09	18.29	20.48	22.68	24.87													
	2750	0.34	0.54	0.75	0.95	1.16	1.29	1.50	1.70	1.90	2.11	2.31													
114		3.87	6.19	8.51	10.83	13.15	14.70	17.02	19.34	21.66	23.98	26.30													
	2900	0.36	0.57	0.79	1.01	1.22	1.37	1.58	1.80	2.01	2.23	2.44													
120		4.08	6.52	8.97	11.42	13.86	15.49	17.94	20.39	22.83	25.28	27.73													
	3050	0.38	0.61	0.83	1.06	1.29	1.44	1.67	1.89	2.12	2.35	2.58													

OPENING HEIGHT inches (mm)



Scan for more product information.

Pressure Drop

Louver test size 48" x 48" (120mm x 120mm). Tested per AMCA 500-L-15 Fig. 5.5. Standard air density @ 0.075 lbs/ft³.

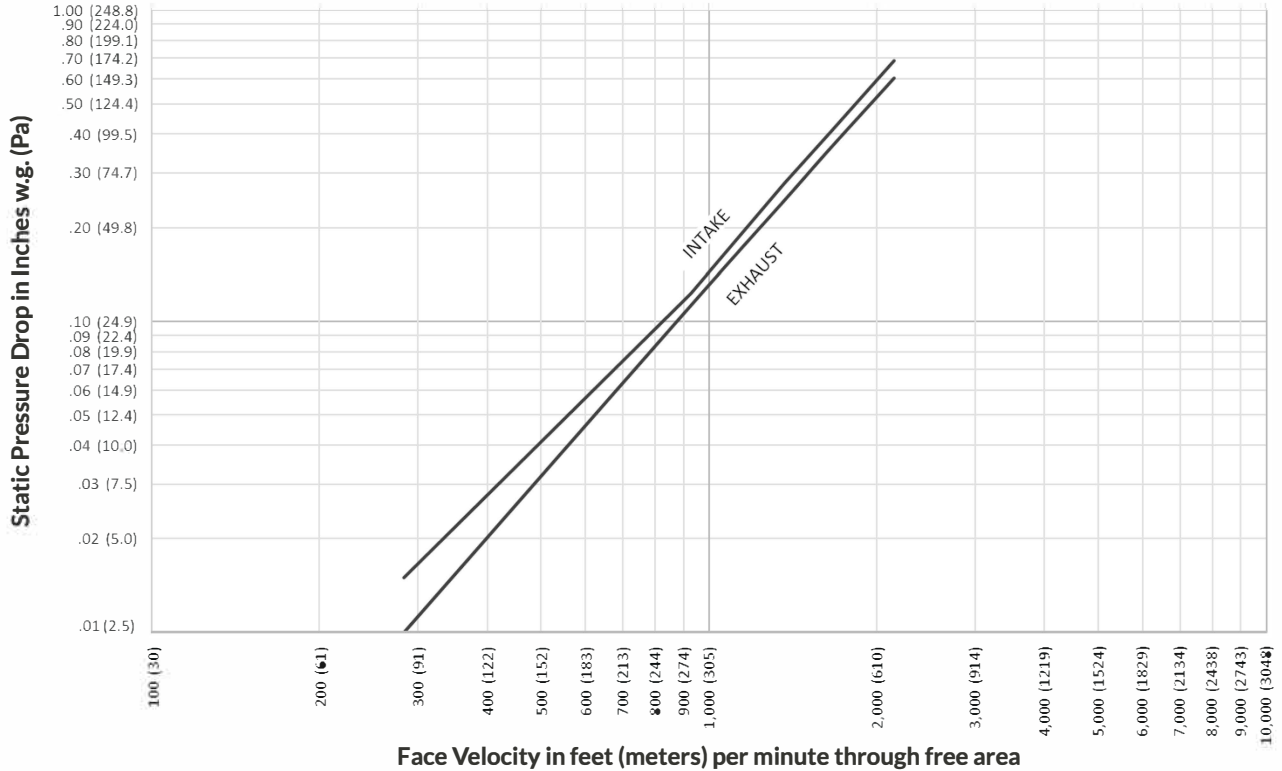

Water Penetration

Louver test size 48" x 48" (120mm x 120mm). Tested per AMCA 500-L-15 Fig. 5.6. Standard air density @ 0.075 lbs/ft³.

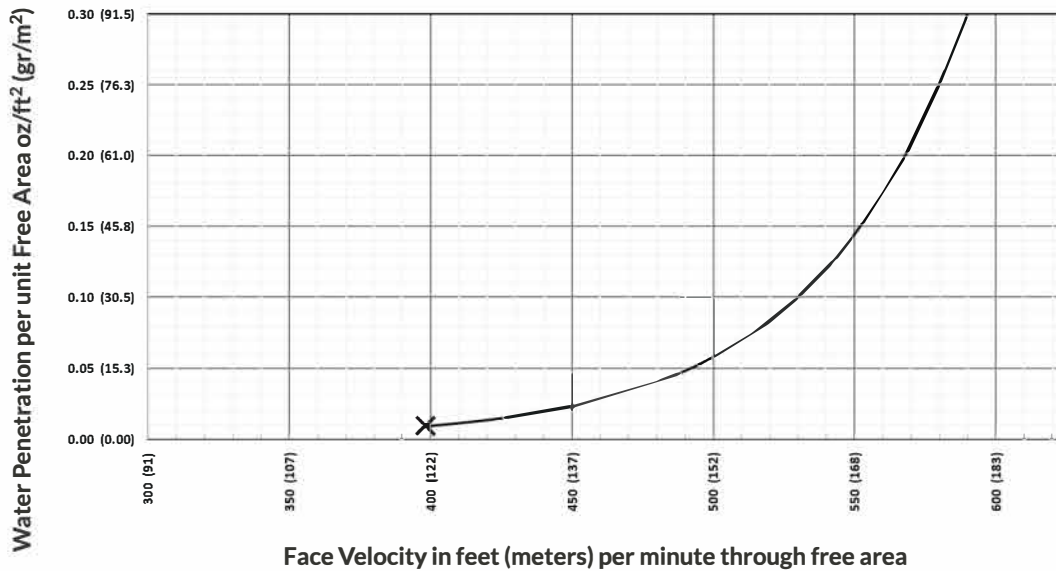

Performance of Louver 48" x 48" (1219mm x 1219mm)

Free Area		Performance at Beginning Point of Water Penetration	
Area	6.86 sq. ft. (0.64 sq. m)	Free Area Velocity	404 fpm
		Max Intake Volume	2,771 CFM
Percent	43%	Performance at 6,638 CFM Intake	
		Pressure Drop	0.123 w.g.



Dayus Register & Grille Inc. certifies that the Model DAL2-CF shown herein is licensed to bear the AMCA Certified Ratings Program seal. The ratings shown are based on tests and procedures performed in accordance with AMCA Publication 511 and comply with the requirements of the AMCA Certified Ratings Program. Louvers were tested in accordance with AMCA Standard 500-L. (Test Figures 5.5-5.6). Louver test size 48 x 48". The AMCA Certified Ratings Program seal applies to Water Penetration and Air Performance ratings.



Scan for more product information.