

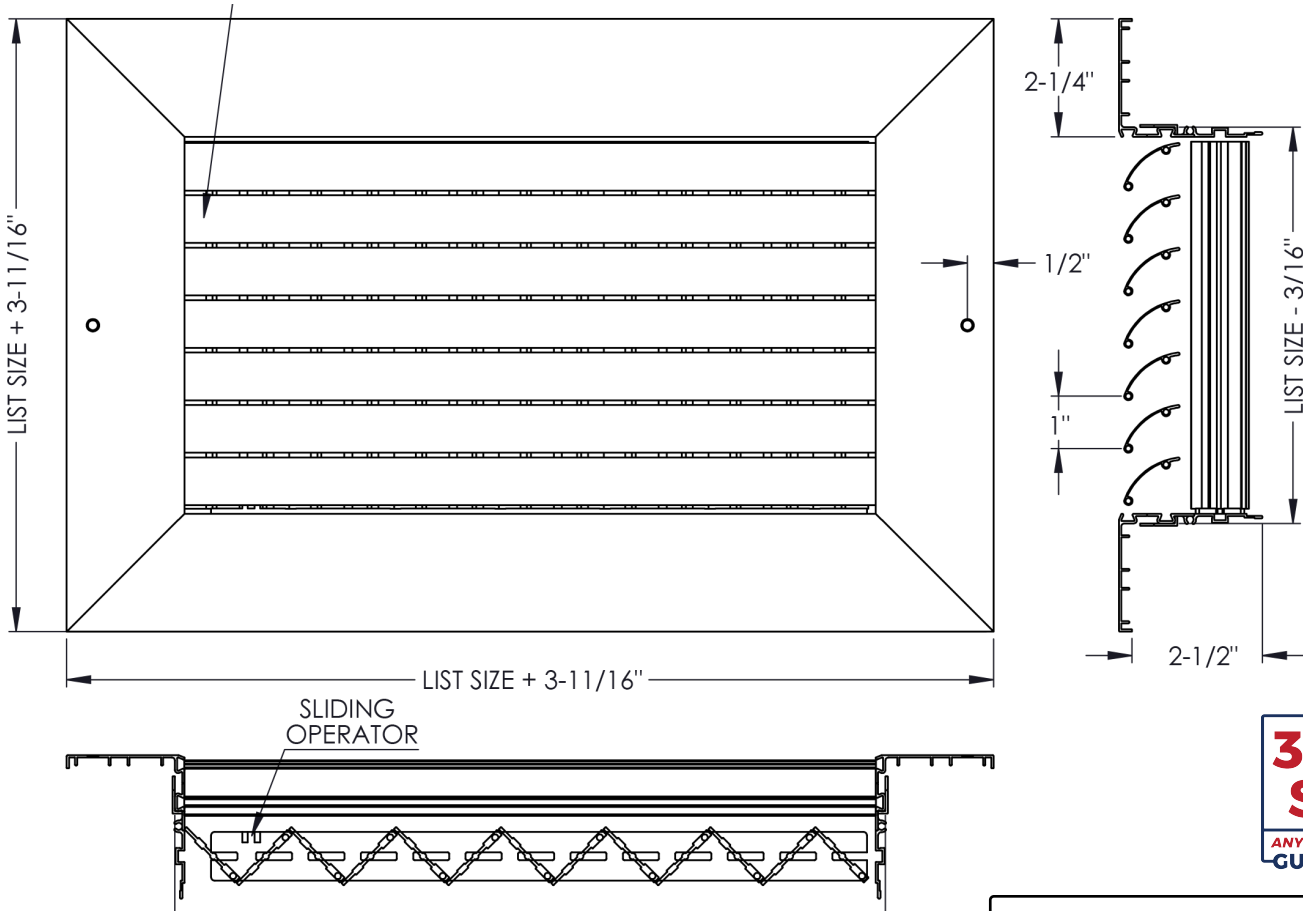

- Wide flange for additional surface coverage.
- Horizontal blades fixed on 30° deflection with 1" spacing.
- Opposed blade damper with slide operator.
- Roll-formed aluminum blades provide stylish appearance.
- Pressure-fit nylon pivot pins provide rattle-free performance.
- High-quality aluminum extruded frame.
- Countersunk #6 screw hole mounting c/w painted screws.
- Mullions used for sizes over 22" in length.
- Available on 2" increments as standard. Custom sizes available down to 1/16" increments.
- Available with durable powder coat finish.



**3 DAY SHIP**  
ANY SIZE. ANY MODEL.  
GUARANTEED

- Additional Options**
- TB - No Screw Holes
  - IS - Insect Screen
  - AA - All Aluminum

**1. Specify the Length x Height Dimensions**

Inches  MM \_\_\_\_\_ x \_\_\_\_\_

**2. Select a Finish**

- W - White
- S - Silver
- M - Mill

**3. Select a Lead Time**

- 3 Day Ship
- Next Friday
- Standard Delivery

**Project / Location:** \_\_\_\_\_

**Architect:** \_\_\_\_\_

**Engineer:** \_\_\_\_\_

**Contractor:** \_\_\_\_\_

