

- Heavy-duty, extruded aluminum channel frame.
- Fully-extruded aluminum louver with fixed 30° horizontal blades on 3/4" spacing.
- Supports are hidden behind blades for a clean appearance.
- No mounting as standard. Mounting can be specified.
- Bird screen included standard. Insect screen can be specified.
- Mounting available for PTAC / VTAC application.
- High-quality powder coat paint as standard (AAMA 2604). Architectural-grade finish available (AAMA 2605).
- 73% free area for optimal performance.

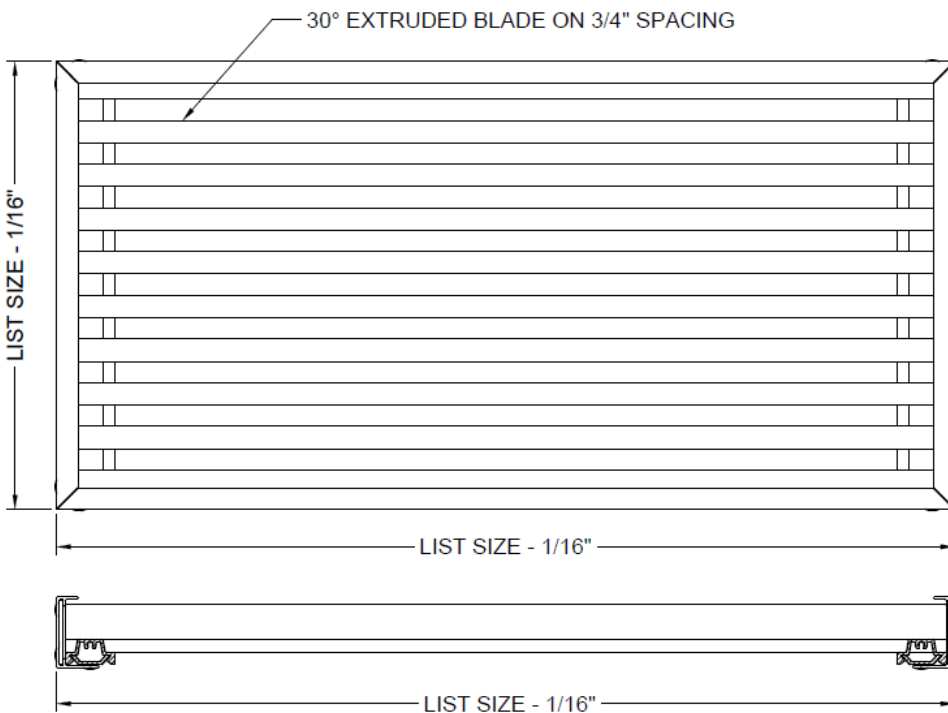

Standard Construction

Y Blade Option

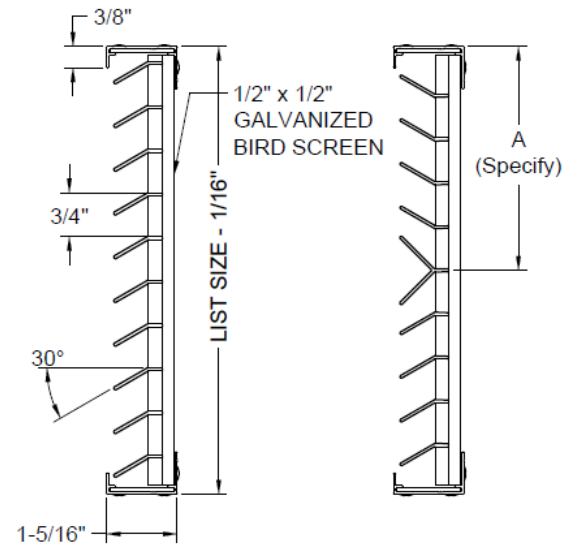

3 DAY SHIP
ANY SIZE. ANY MODEL. GUARANTEED.

1. Specify Quantity

2. Specify the Length x Height Dimensions

Available on 1" increments as standard. Custom sizes down to 1/16" increments.

_____ x _____ inches mm

3. Select a Finish

AAMA 2605 powder coat finish available upon request.

- | | |
|--|---|
| <input type="checkbox"/> <u>W</u> - White | <input type="checkbox"/> <u>M</u> - Mill |
| <input type="checkbox"/> <u>S</u> - Silver | <input type="checkbox"/> <u>FB</u> - Flat Black |
| <input type="checkbox"/> <u>B</u> - Brown | <input type="checkbox"/> <u>Special</u> : |

4. Select a Lead Time

3 Day Ship available on mill finish only.

- 3 Day Ship
- Next Friday
- Standard Delivery

Additional Options

- Y - Y Blade Must specify location.
- IS - Insect Screen
- A - Mounting Holes
- B - Rear Wall Sleeve Mount
Mounting configuration drawing needed.

Project / Location:

Architect:

Engineer:

Contractor:



Scan for more product information.

Mounting

-A

Mounting Holes

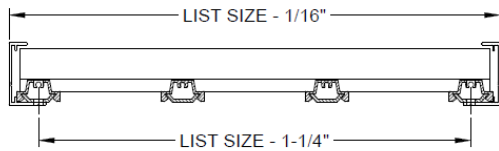
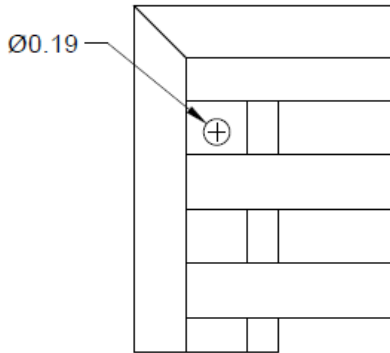

-B

Rear Wall Sleeve Mounting
Specifying drawing of hole locations required.

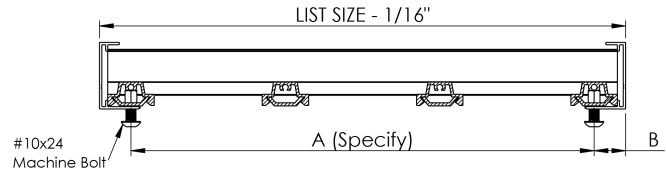
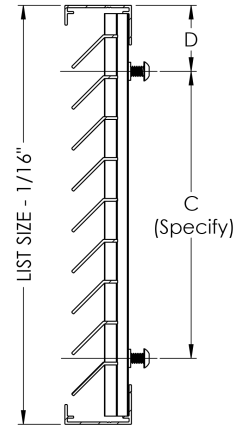

Special Options

Specifying drawings required.

Y-Blade

For combination intake/exhaust units.

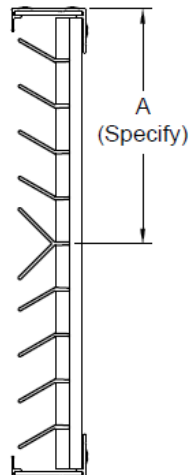

Scan for more product information.

Free Area ft² (m²)

OPENING LENGTH inches (mm)

OPENING HEIGHT inches (mm)	OPENING LENGTH inches (mm)																			
	12 300	18 450	24 600	30 750	36 900	42 1050	48 1200	54 1350	60 1500	66 1700	72 1850	78 2000	84 2150	90 2300	96 2450	102 2600	108 2750	114 2900	120 3050	
8 200	0.40 0.04	0.64 0.06	0.85 0.08	1.10 0.10	1.34 0.12	1.55 0.14	1.80 0.17	2.05 0.19	2.25 0.21	2.50 0.23	2.75 0.26	2.96 0.27	3.20 0.30	3.45 0.32	3.66 0.34	3.90 0.36	4.15 0.39	4.36 0.40	4.60 0.43	
12 300	0.61 0.06	0.98 0.09	1.30 0.12	1.67 0.16	2.05 0.19	2.37 0.22	2.74 0.25	3.12 0.29	3.43 0.32	3.81 0.35	4.18 0.39	4.50 0.42	4.88 0.45	5.25 0.49	5.57 0.52	5.94 0.55	6.32 0.59	6.64 0.62	7.01 0.65	
16 450	0.83 0.08	1.34 0.12	1.77 0.16	2.28 0.21	2.79 0.26	3.22 0.30	3.73 0.35	4.24 0.39	4.67 0.43	5.18 0.48	5.69 0.53	6.12 0.57	6.63 0.62	7.14 0.66	7.58 0.70	8.08 0.75	8.59 0.80	9.03 0.84	9.54 0.89	
20 600	1.05 0.10	1.69 0.16	2.24 0.21	2.88 0.27	3.53 0.33	4.07 0.38	4.72 0.44	5.36 0.50	5.91 0.55	6.55 0.61	7.20 0.67	7.75 0.72	8.39 0.78	9.03 0.84	9.58 0.89	10.23 0.95	10.87 1.01	11.42 1.06	12.06 1.12	
24 750	1.27 0.12	2.04 0.19	2.71 0.25	3.49 0.32	4.26 0.40	4.93 0.46	5.71 0.53	6.49 0.60	7.15 0.66	7.93 0.74	8.71 0.81	9.37 0.87	10.15 0.94	10.93 1.02	11.59 1.08	12.37 1.15	13.15 1.22	13.81 1.28	14.59 1.36	
28 900	1.48 0.14	2.40 0.22	3.18 0.30	4.09 0.38	5.00 0.46	5.78 0.54	6.70 0.62	7.61 0.71	8.39 0.78	9.30 0.86	10.21 0.95	10.99 1.02	11.91 1.11	12.82 1.19	13.60 1.26	14.51 1.35	15.42 1.43	16.20 1.51	17.12 1.59	
32 1050	1.70 0.16	2.75 0.26	3.65 0.34	4.69 0.44	5.74 0.53	6.64 0.62	7.68 0.71	8.73 0.81	9.63 0.89	10.67 0.99	11.72 1.09	12.62 1.17	13.66 1.27	14.71 1.37	15.61 1.45	16.65 1.55	17.70 1.64	18.60 1.73	19.64 1.83	
36 1200	1.91 0.18	3.09 0.29	4.09 0.38	5.27 0.49	6.45 0.60	7.45 0.69	8.63 0.80	9.80 0.91	10.81 1.00	11.98 1.11	13.16 1.22	14.16 1.32	15.34 1.43	16.52 1.53	17.52 1.63	18.70 1.74	19.87 1.85	20.88 1.94	22.05 2.05	
40 1350	2.13 0.20	3.44 0.32	4.56 0.42	5.87 0.55	7.18 0.67	8.30 0.77	9.61 0.89	10.93 1.01	12.04 1.12	13.36 1.24	14.67 1.36	15.79 1.47	17.10 1.59	18.41 1.71	19.53 1.81	20.84 1.94	22.15 2.06	23.27 2.16	24.58 2.28	
44 1500	2.35 0.22	3.80 0.35	5.03 0.47	6.48 0.60	7.92 0.74	9.16 0.85	10.60 0.99	12.05 1.12	13.28 1.23	14.73 1.37	16.17 1.50	17.41 1.62	18.85 1.75	20.30 1.89	21.53 2.00	22.98 2.13	24.43 2.27	25.66 2.38	27.11 2.52	
48 1700	2.57 0.24	4.15 0.39	5.50 0.51	7.08 0.66	8.66 0.80	10.01 0.93	11.59 1.08	13.17 1.22	14.52 1.35	16.10 1.50	17.68 1.64	19.03 1.77	20.61 1.91	22.19 2.06	23.54 2.19	25.12 2.33	26.70 2.48	28.05 2.61	29.63 2.75	
52 1850	2.79 0.26	4.50 0.42	5.97 0.55	7.68 0.71	9.40 0.87	10.86 1.01	12.58 1.17	14.29 1.33	15.76 1.46	17.47 1.62	19.19 1.78	20.65 1.92	22.37 2.08	24.09 2.24	25.55 2.37	27.27 2.53	28.98 2.69	30.45 2.83	32.16 2.99	
56 2000	3.01 0.28	4.86 0.45	6.44 0.60	8.29 0.77	10.14 0.94	11.72 1.09	13.57 1.26	15.42 1.43	17.00 1.58	18.85 1.75	20.70 1.92	22.13 1.87	23.66 2.06	25.15 2.24	26.66 2.42	28.17 2.59	29.67 2.75	31.11 2.91	32.59 3.07	
60 2150	3.22 0.30	5.20 0.48	6.88 0.64	8.86 0.82	10.84 1.01	12.53 1.16	14.51 1.35	16.49 1.53	18.18 1.69	20.16 1.87	22.13 2.06	23.66 2.24	25.15 2.42	26.66 2.59	28.17 2.75	29.67 2.91	31.11 3.07	32.59 3.23	34.01 3.39	
64 2300	3.44 0.32	5.55 0.52	7.35 0.68	9.47 0.88	11.58 1.08	13.38 1.24	15.50 1.44	17.61 1.64	19.42 1.80	21.53 2.00	23.64 2.20	25.15 2.39	26.66 2.58	28.17 2.77	29.67 2.96	31.11 3.15	32.59 3.34	34.01 3.53	35.43 3.69	
68 2450	3.65 0.34	5.90 0.55	7.82 0.73	10.07 0.94	12.32 1.14	14.24 1.32	16.49 1.53	18.73 1.74	20.65 1.92	22.90 2.13	25.15 2.34	26.66 2.53	28.17 2.72	29.67 2.91	31.11 3.10	32.59 3.29	34.01 3.48	35.43 3.67	36.85 3.86	
72 2600	3.87 0.36	6.26 0.58	8.29 0.77	10.67 0.99	13.06 1.21	15.09 1.40	17.48 1.62	19.86 1.84	21.89 2.03	24.28 2.26	26.66 2.48	28.17 2.67	29.67 2.86	31.11 3.05	32.59 3.24	34.01 3.43	35.43 3.62	36.85 3.81	38.27 4.00	
76 2750	4.09 0.38	6.61 0.61	8.76 0.81	11.28 1.05	13.80 1.28	15.95 1.48	18.46 1.72	20.98 1.95	23.13 2.15	25.65 2.38	28.17 2.62	29.67 2.81	31.11 3.00	32.59 3.19	34.01 3.38	35.43 3.57	36.85 3.76	38.27 3.95	39.69 4.14	
80 2900	4.31 0.40	6.96 0.65	9.23 0.86	11.88 1.10	14.53 1.35	16.80 1.56	19.45 1.81	22.10 2.05	24.37 2.26	26.66 2.51	29.67 2.76	31.11 2.95	32.59 3.14	34.01 3.33	35.43 3.52	36.85 3.71	38.27 3.90	39.69 4.09	41.11 4.23	
84 3050	4.52 0.42	7.30 0.68	9.68 0.90	12.46 1.16	15.24 1.42	17.61 1.64	20.39 1.89	23.17 2.15	25.55 2.37	28.33 2.63	31.11 2.89	32.59 3.08	34.01 3.27	35.43 3.46	36.85 3.65	38.27 3.84	39.69 4.03	41.11 4.22	42.53 4.41	

Pressure Drop Louver test size 48" x 48" (120mm x 120mm).

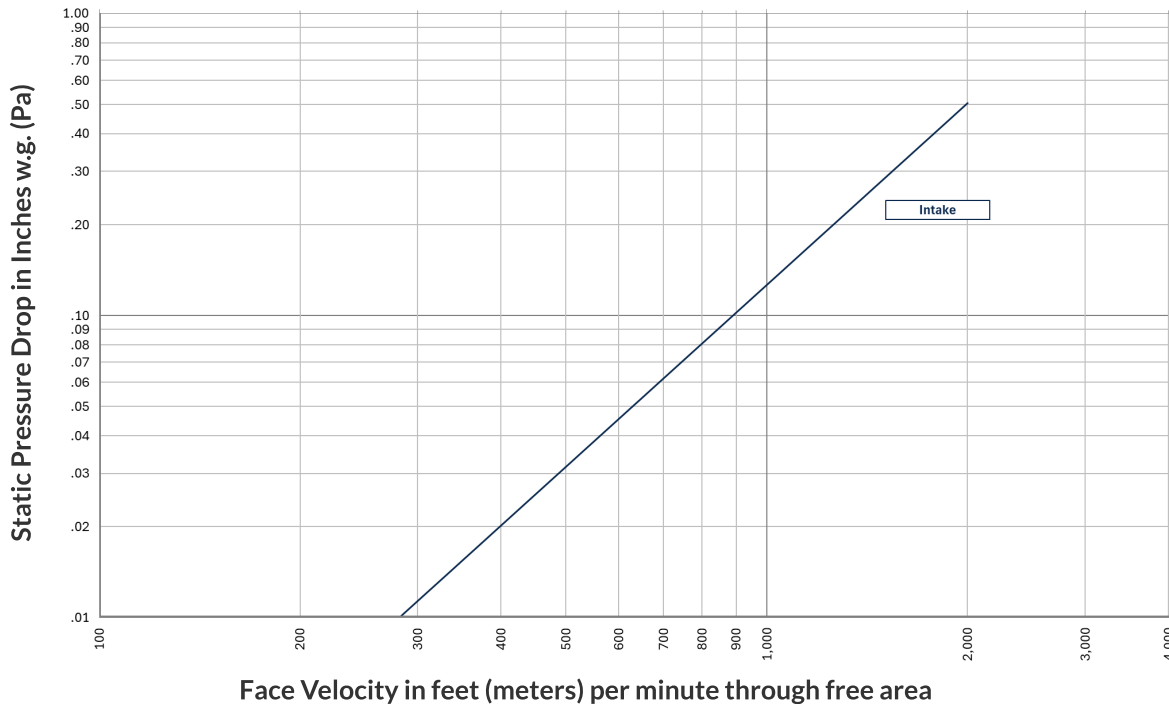

Scan for more product information.