

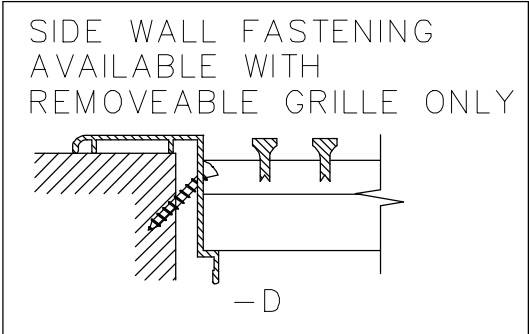

OF BLADES=(LIST SIZE-1)*2+1



	Dayus Register & Grille Inc. 5290 Pulleyblank St., Windsor On. N9A 6J3 Phone (519) 737-1199 Fax (519) 737-1831 www.dayus.com Email sales@dayus.com	
	MODEL NO. DABLR-30-D	
PRODUCT DESCRIPTION BAR LINEAR REMOVEABLE GRILLE - SIDEWALL MOUNTING		
FACE BLADES HORIZONTAL FIXED	BLADE TYPE 30° DEFLECTION	
DAMPERS N/A	MATERIAL ALUMINUM	
FINISH WHITE/SILVER/BROWN	DATE REVISED 6/28/07	
FILE NAME 021 PDF Drawings\09 Bar Linear\080310 DABLR-30-D.DWG		